

## Sliding Mode Control for Humidity and Temperature Control in an Evaporative Cooling System of a Poultry house

Kritsadang Senawong<sup>1</sup>, Ratchapol Suntivarakorn<sup>1</sup>, and Thana Radpukdee<sup>2\*</sup>

<sup>1</sup>Mechanical Engineering Department, Faculty of Engineering, Khon Kaen University,  
Khon Kaen, Thailand 40002

<sup>2</sup>Industrial Engineering Department, Faculty of Engineering, Khon Kaen University,  
Khon Kaen, Thailand 40002

\*Corresponding Author: Tel: 086 4556358, Fax: 043 202 849

E-mail: [krit\\_jae@hotmail.com](mailto:krit_jae@hotmail.com)<sup>1</sup>, [ratchaphon@kku.ac.th](mailto:ratchaphon@kku.ac.th)<sup>1</sup>, [tthanar@gmail.com](mailto:tthanar@gmail.com)<sup>2</sup>

### **Abstract**

This paper presents a control method based on the well known sliding mode control for temperature and humidity control in an evaporative cooling system of a poultry house. The control method can compensate for changing of ambient air condition of the house. A control law of the method was designed from mathematical models which are mass and energy balance relations of air and water of the system. To validate the mathematical model, its responses were compared with a real system. And the model was simulated in case of summer condition to study its behavior and demonstrate ability of the proposed control technique.

**Key words:** Sliding mode control, Evaporative cooling control, Poultry house

### **Nomenclature**

$A$	Heat exchanger evaporation area of cooling pad ( $m^2$ )	$t$	Time (s)
$C_p$	Specific Heat of air	$T_{in}$	Inside air temperature ( $^{\circ}C$ )
$C_{pu}$	Specific Heat ( $J/kg.K$ )	$T_{out}$	Outside air temperature ( $^{\circ}C$ )
$h_c$	Coefficient of heat convection ( $w/m^2 \cdot ^{\circ}C$ )	$V_T, V_H$	Internal air and heat , Given 70% of poultry house size 14x125x4 $m^3$
$\dot{m}_{air}$	mass flow rate of air (kg/s)	$V_R$	Air flow rate ( $m^3/s$ )
$\dot{m}_{water}$	mass flow rate of water (kgwater/s)	$w_{an}$	Humidity ratio from animal (kg/h)
$N_{an}$	Number of animal(unit)	$w_{ch}$	Humidity ratio from chicken ( $g_{H_2O}/s$ )
$P$	Air pressure (kPa)	$w_{ev}$	Humidity ratio from evaporate water ( $g_{H_2O}/s$ )
$P_g$	Saturated air pressure (kPa)	$w_{in}$	Humidity ratio out the poultry house ( $g_{H_2O}/s$ )
$Q_{an}$	Sensible heat from animal (kW)	$w_{air out}$	Humidity ratio from ambient air into the poultry house ( $g_{H_2O}/s$ )
$Q_c$	Heat load from the Ceiling and Wall into the poultry house (kW)	$\rho_{air}$	Air density, Given 1.2 $kg/m^3$
$Q_{ch}$	Sensible and latent heat from chicken (kJ/s)	$\lambda$	Latent heat ( $kJ/g_{H_2O}$ )
$Q_{ev}$	Heat used to evaporate water (kW)	$\epsilon_{sat}$	Saturation effectiveness
$Q_v$	Heat loss from ventilation (kW)		

### 1. Introduction

Currently, the number of domestic poultry house has to change a type of poultry house from open system to controlled environment house. Which it have to used Evaporative Air-Conditioning System for an appropriated of temperature and moisture content. That it will result in a higher volume of production per unit. If we design Temperature and Moisture Controller System have to appropriate. This will increases the efficiency of poultry house and also helps in terms of energy efficiency from used of equipment in Evaporative Air-Conditioning System properly. As a result have enormous value from reducing of energy imports, increase productivity and exports.

Researchers are interested to study controlled environment house in terms of creating mathematical modeling of poultry house and operation of poultry house controller system. To be design operation controller of equipment in poultry house for higher efficiency than old system. High quality of Temperature and Moisture Controller System as a result of optimization and increase productivity. In Section 2, it is proposed to created mathematical modeling was led to comparisons with a case study of chicken farm (Figure 1) and show compare the result in Section 3, And Section 4 is a mathematical modeling to simulate control system.

### 2. Mathematical Modeling of an Evaporative Air-conditioning System

In this part is consider in direct evaporative cooling process on the basis of Figure 2.



Figure 1 The poultry house in this study (a case study of chicken farm in Khon Kaen, Thailand)

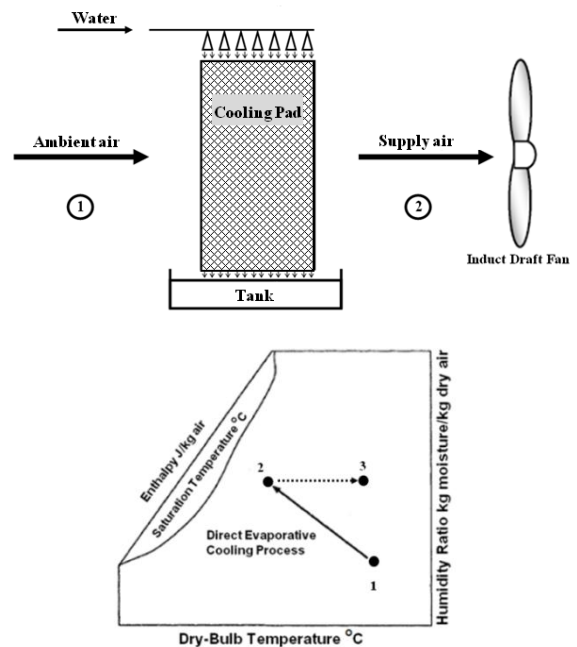

Figure 2 Direct Evaporative Cooling system and Psychrometric chart illustrating the constant enthalpy Process for

Outside air is cooled and more moisture from direct contact with Cooling pad, which is Evaporative Air-Conditioning System Process. When we considering the hypothesis that no loss of heat to the environment during when adiabatic process. So some sensible heat from outside air is transformed are latent heat for evaporation, as show in Figure 3.

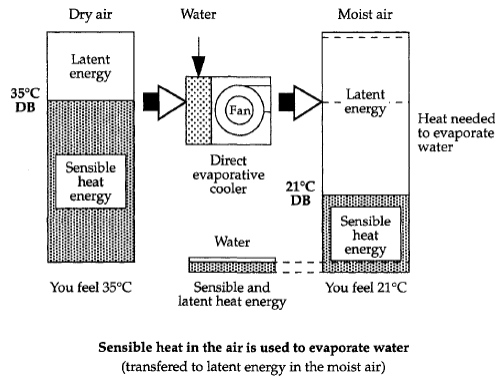

Figure 3 Simplified Evaporative Air-Conditioning Process [Bom, Gret Jan and etc., 1999]

This process are show in Block diagram in Figure 4, saturated air occur when air from State1. pass Cooling pad into State2. If Cooling pad are 100% in State2. Can be Perfect Saturation which Relative humidity are 100%RH . However, It is not certainly in practical. And from State2. to State3. are increase heat process will causes Relative humidity are decreases. Cooled air from Cooling pad at State2. (Assume Haven't moisture absorption in poultry house) is mixed air in poultry house. When the mixture reaches the required temperature is removed from poultry house.

Assume Air and Stream as the Perfect gases at mass flow rate of air ( $\dot{m}_a$ ) can be determined Cooling load [Bom, Gret Jan and etc., 1999]

$$\text{Cooling load} = \text{Mass Flow rate} [\text{Enthalpy of state(3)} - \text{Enthalpy of state(2)}]$$

$$\begin{aligned} \dot{Q}_{latent} + \dot{Q}_{sensible} &= \dot{m}_a C_{pu} [T_3 - T_2] \\ \dot{Q}_{Total} &= \dot{m}_a C_{pv} [T_3 - T_2] \end{aligned} \quad (1)$$

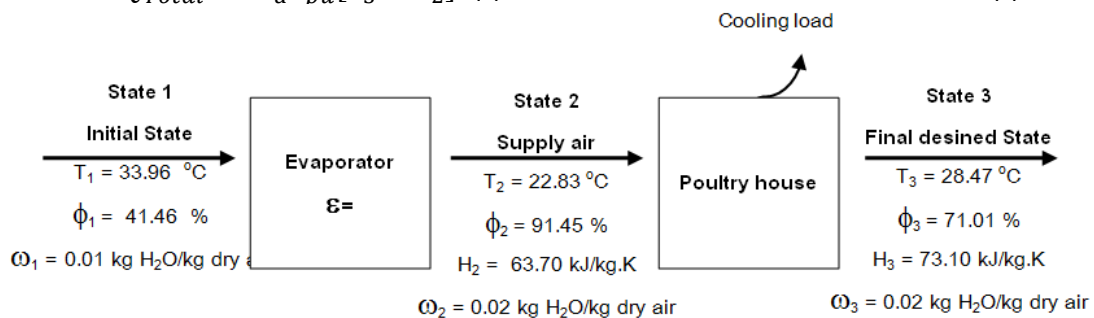

Figure 4 Schematic of the Ideal Steady State Evaporative Cooling Process.

When

$$C_{pu} = C_{pa} + \omega C_{pv} \text{ is Specific Heat of wet air.}$$

Considering Eq.1 Given  $\dot{m}_a$  are Output is

$$T_3 = \frac{\dot{Q}_{Total}}{C_{pu}} \frac{1}{\dot{m}_a} + T_2 \quad (2)$$

From Eq.2 can be considering is  $1/\dot{m}_a$  and  $T_2$  are Input of system. Considering relation of Cooling pad efficiency :  $\epsilon$  That ( $T_1 - T_{wb1}$  is Wet bulb depression)

$$\epsilon = \frac{T_1 - T_2}{T_1 - T_{wb1}} \quad (3)$$

or

$$T_2 = T_1 - \epsilon [T_1 - T_{wb1}] \quad (4)$$

$\epsilon$  have to be directed relation with  $T_2$  and  $\epsilon$  have to be relation with speed of wind as pass Cooling pad at Exponential decay. Show in Figure 5

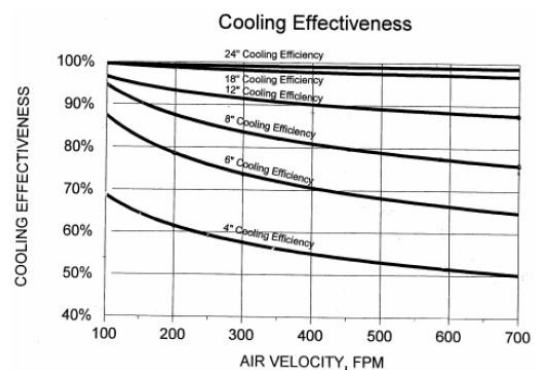

Figure 5 Characteristic curves for effectiveness [João M. D. Pimenta, Wagner P. De Castro]

$$\varepsilon = 1 - e^{\left[\frac{-h_c A}{\dot{m}_a C_{pu}}\right]} \quad (5)$$

When

$h_c$  is Coefficient of heat convection ( $W/m^2 \cdot ^\circ C$ )

$A$  is Heat exchanger evaporation area of cooling pad ( $m^2$ )

$C_{pu}$  is Specific Heat (J/kg.K)

Given  $C_{pa} = 1006$  J/kg.K ,

$C_{pv} = 1805$  J/kg.K

$\dot{m}_a$  is mass flow rate of air (kg/s)

In Eq.5  $\varepsilon$  are fixed rate if  $\dot{m}_a$  be stable. We can controlable  $\varepsilon$  from  $\dot{m}_a$ . If considered Eq.2, Eq.5 Eq.5 be the series of response equation is Poultry house Temperature ( $T_3$ ) and Control signals is  $\dot{m}_a$

$$T_3 = \frac{Q_{Total}}{C_{pu}} \frac{1}{\dot{m}_a} + T_{wb1} + [T_1 - T_{wb1}] e^{\left[\frac{-h_c A}{\dot{m}_a C_{pu}}\right]} \quad (6)$$

From Eq.6 we can determined Poultry house Temperature ( $T_3$ ) from Heat load ( $Q_{Total}$ ) . However Heat load environment has changed over time. This method can be form feed forward control system. It is not respondable quickly to changing environments. If we update heat load all time. It is difficult to enforce. System converges to the reference. Because there is no compensation for the use of a model error of the heat load [Camargo et al, 2005] In order to design a feedback control system. The balance of mass and energy is considered.

#### Energy balance

Energy input – Energy output = Internal energy changes

#### Mass balance

Water input – Water output = Internal humidity changes

Can be expressed as

$$\rho_{air} C_p V_T \frac{dT_{in}}{dt} = Q_{chick} + Q_{evap} - Q_{vent} - Q_{ev} \quad (7)$$

$$\rho_{air} V_H \frac{dw_{in}}{dt} = w_{chick} + w_{air out} + w_{ev} - w_{in} \quad (8)$$

When

$\rho_{air}$  is Air density, Given  $1.2$  kg/m<sup>3</sup>

$C_p$  is Specific Heat of air,

Given  $1.005$  kJ/(kg.K)

$V_T, V_H$  is Internal air and heat , Given 70% of poultry house size  $14 \times 125 \times 4$  m<sup>3</sup>

$T_{in}$  is Internal Temperature ( $^\circ C$ )

$t$  is Time (s)

$Q_{ch}$  is Sensible and latent heat from chicken (kJ/s)

$Q_c$  is Heat load from the Ceiling and Wall into the poultry house (kW)

$Q_v$  is Heat loss from ventilation (kW)

$Q_{ev}$  is Heat used to evaporate water (kW)

$w_{in}$  is Humidity ratio in the poultry house ( $g_{H_2O}/kg_{dry air}$ )

$w_{ch}$  is Humidity ratio from chicken ( $g_{H_2O}/s$ )

$w_{air out}$  is Humidity ratio from ambient air into the poultry house ( $g_{H_2O}/s$ )

$w_{ev}$  is Humidity ratio from evaporate water ( $g_{H_2O}/s$ )

$w_{in}$  is Humidity ratio out the poultry house ( $g_{H_2O}/s$ )

From equation (7) and (8) will be detailed as following.

### 2.1 Sensible and latent heat from chicken ( $Q_{ch}$ ) and Humidity from chicken ( $w_{ch}$ )

Data from a case study of chicken farm that 1 of chicken will be occur heat and water 10

Btu/hr and 70% x 150 cc./day. However That can be considered from The experience of experts. And that will assuming the equation of Daskalov [2005] ,Which the piglets weighing 2 kg. and chicken weighing 2 kg. as 60000 piggy=6000 piglets. Instead Daskalov's Equation. There are little discrepancies but this objective thesis want to be an approach to design automatic control system type Robust Adaptive Control. So, This tolerances are compensated by the performance of the system or if there is a relationship of heat and water temperature in the poultry house

$$Q_{an} = N_{an} \times 0.096 \times [0.8 - 1.85 \times 10^{-7}(T_{in} + 10)^4] \quad (9)$$

$$w_{\text{animal}} = N_{an} \times 0.001 \times [0.26T_{in}^2 - 6.465T_{in} + 81.6] \quad (10)$$

When

$N_{an}$  is Number of animal(unit)

$Q_{an}$  is Sensible heat from animal (kW)

$T_{in}$  is Internal temperature ( $^{\circ}\text{C}$ )

$w_{an}$  is Humidity ratio from animal (kg/h)

## 2.2 Heat load from the Ceiling and Wall into the poultry house ( $Q_c$ )

$$Q_{\text{ceiling wall}} = U_A [T_{out} - T_{in}] \quad (11)$$

When

$U_A$  is Coefficient of heat convection (kW/K)

Given 0.712 kW/K [Soldatas et al. 2005]

$T_{out}$  is Outside air temperature ( $^{\circ}\text{C}$ )

## 2.3 Heat loss from ventilation ( $Q_v$ )

$$Q_{\text{ventilation}} = \rho_{air} V_R C_p [T_{out} - T_{in}] \quad (12)$$

When

$V_R$  is Air flow rate ( $\text{m}^3/\text{s}$ )

## 2.4 Heat used to evaporate water ( $Q_{ev}$ )

$$Q_{\text{evaporation}} = \lambda w_{ev} \quad (13)$$

When

$\lambda$  is Latent heat (2.257 kJ/g $\text{H}_2\text{O}$ )

## 2.5 Humidity ratio from ambient air into the poultry house ( $w_{air out}$ )

$$w_{air out} = \rho_{air} V_R w_{out} \quad (14)$$

## 2.6 Humidity ratio out the poultry house ( $w_{air in}$ )

$$w_{air in} = \rho_{air} V_R w_{in} \quad (15)$$

When

$w_{air out}, w_{air in}$  is Internal and External absolute humidity (g $\text{H}_2\text{O}$ /kg $\text{dryair}$ )

From equation (9) - (15) into equation

(16) and (17) is that

$$\frac{dT_{in}}{dt} = \frac{N_{an} \times 0.096 \times [0.8 - 1.85 \times 10^{-7}(T_{in} + 10)^4] + U_A [T_{out} - T_{in}] - \lambda w_{ev}}{\rho_{air} C_p V_T} - \frac{V_R}{V_T} [T_{out} - T_{in}] \quad (16)$$

$$\frac{dw_{in}}{dt} = \frac{N_{an} \times 0.001 \times [0.26T_{in}^2 - 6.465T_{in} + 81.6] + w_{ev}}{\rho_{air} V_H} - \frac{V_R}{V_T} [w_{in} - w_{out}] \quad (17)$$

From equation (16) and (17) instead of the parameters will be

$$\frac{dT_{in}}{dt} = [77.76 - 1.801 \times 10^{-5}(T_{in} + 10)^4] \times 10^{-3} + 0.12036 \times 10^{-3} [T_{out} - T_{in}] - 0.1059 \times 10^{-3} w_{ev} - \frac{[T_{out} - T_{in}] V_R}{4900} \quad (18)$$

$$\frac{dw_{in}}{dt} = \frac{[0.265T_{in}^2 - 6.5918T_{in} + 83.26] \times 10^{-3}}{3600} + 4.72 \times 10^{-8} w_{ev} - \frac{V_R}{4900} [w_{in} - w_{out}] \quad (19)$$

### 3. Comparison and Result

To verify the accuracy of the mathematical model, researcher was conducted to measure and store temperature data, absolute

humidity of climate in the house. It has control the ventilation fan and switching of water pump for control incoming water on the system as shown as Figure 6

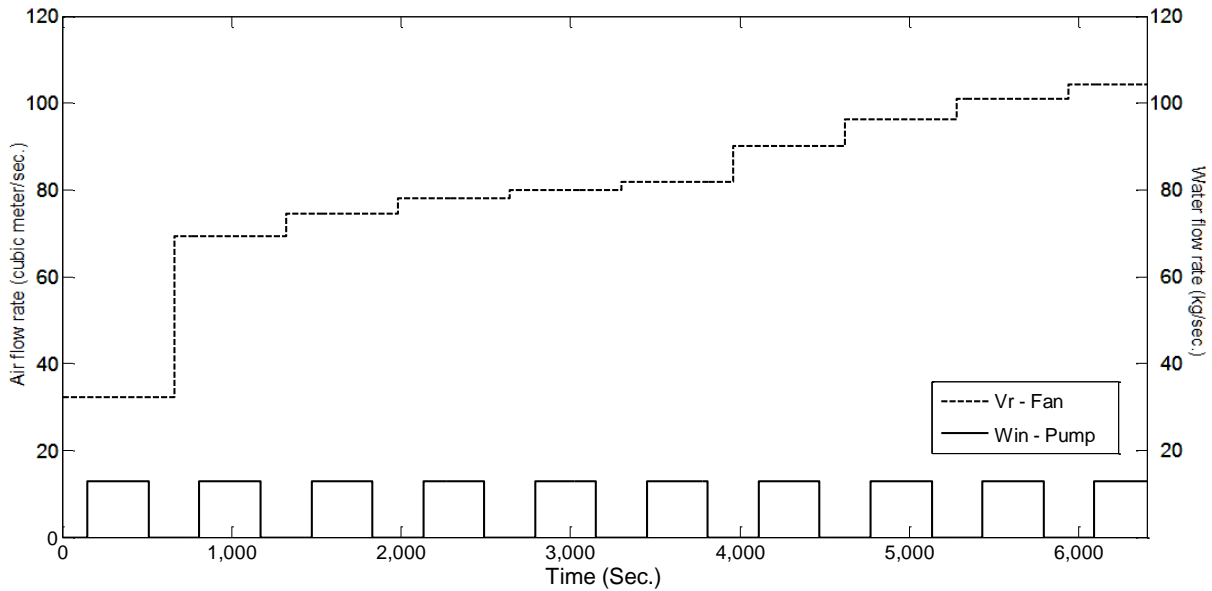

Figure 6 Air flow rate ( $m^3/s$ ) and water flow rate (kg/s)

From Figure 6 shown that researcher was define controller the ventilation of fan. By increasing the rate of air flow which base on fan's capability there is 32.2, 69.23, 74.52, 78.15, 79.75, 81.88, 90.16, 96.28, 101.02, and 104.37 respectively. In each range of air flow was turn on pump in order to the water spread to the cooling pad for 6 minutes. And tune off

pump for 10 minutes before increasing the ventilation. Then conduct temperature data and absolute humidity of climate in the house that obtained from mathematical model shown as Figure 7. Compare with the values that can measure and collect from real operating environment which caparisoned data shown as Figure 8.

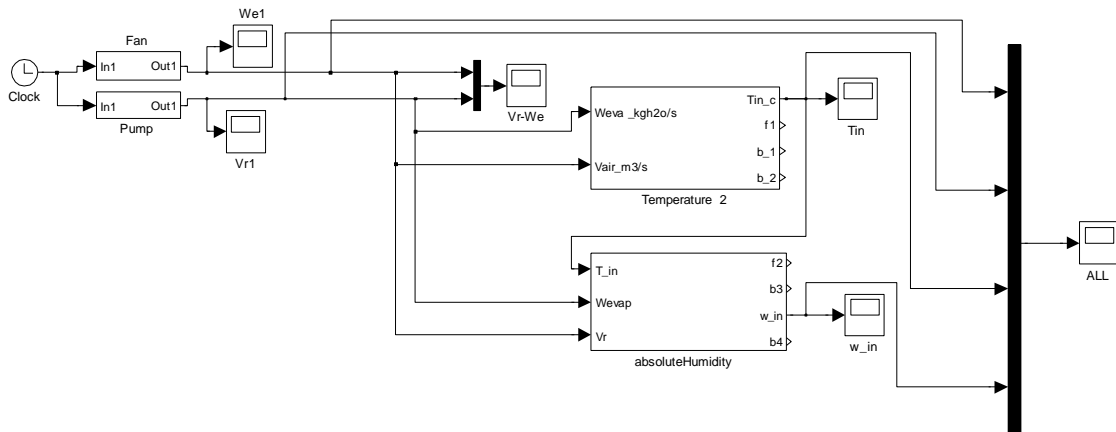
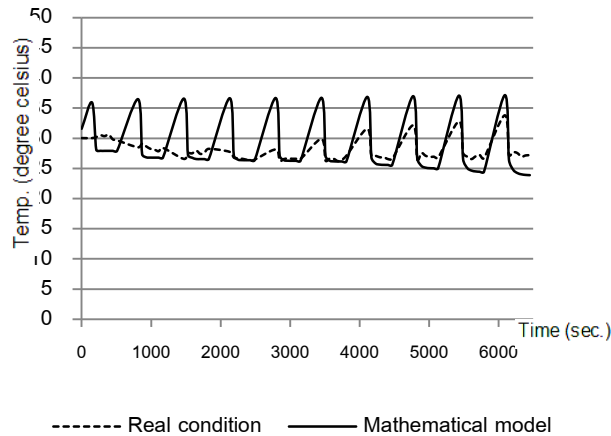
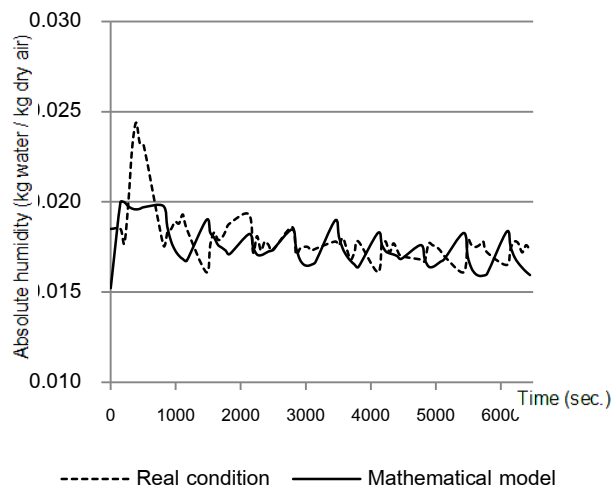

Figure 7 shown Block diagram for testing the value of mathematical models in Matlab simulink.



(a) Temperature [ $^{\circ}\text{C}$ ]



(b) Absolute humidity [ $\text{kg}_{\text{H}_2\text{O}}/\text{kg}_{\text{dry air}}$ ]

Figure 8 shown the comparison of the climate in the house between Mathematical models and Real condition.

From Figure 8 shown that the values of weather condition which obtained from mathematical model is conduct to compare with measured and store values in the house are similar and have a tendency to be in the same direction. Calculated to find the error of temperature values [ $^{\circ}\text{C}$ ] and absolute humidity [ $\text{kg}_{\text{H}_2\text{O}}/\text{kg}_{\text{dry air}}$ ] are 0.5487% and 2.9417 % respectively. This mathematical model has error value which is accuracy can be accept to

simulate in the control system. This can be presented in the next section.

#### 4. CONTROL TEST

Calibrating a mathematical model that created and then designed the rule to control (to be presented in a future article.) Which can simulate controller and shown the performance of the control from Simulation program using the Matlab simulink.

By requiring the

External environment :  $33^{\circ}\text{C}$  40%RH

$$w_{\text{out}} = 12.5 \text{ g}_{\text{H}_2\text{O}}/\text{kg}_{\text{dry air}}$$

Conditions in the house are required :

$$28^{\circ}\text{C} \text{ 70\%RH} \quad w_{\text{out}} = 16.8 \text{ g}_{\text{H}_2\text{O}}/\text{kg}_{\text{dry air}}$$

Define the system has rate of Air change less than  $245 \text{ m}^3 / \text{s}$ . and Water flow rate was less than  $13 \text{ kg} / \text{s}$ . Which is determined from the device are fan and pump. Setting error values from the difference of temperature inside and outside  $\Delta T_{\text{out-in}}$  are  $1 \sin \frac{2\pi}{900} t$  and error values of the difference of moisture inside and outside  $\Delta w_{\text{in-out}}$  are  $1 \times 10^{-3} \sin \frac{2\pi}{900} t$  the results of the simulation control program are shown following

Case 1 If a system has no control.

Case 2 when the system is  $\Delta T_{\text{out-in}}$  and  $\Delta w_{\text{in-out}}$  are zero

Case 3 when the system is  $\Delta T_{\text{out-in}}$  and  $\Delta w_{\text{in-out}}$  are not zero respective given above.

##### 4.1 Case 1 If a system has no control.

In the first case is a simulation program that is not control condition in house. The results of the simulation program are shown as Figure 10.

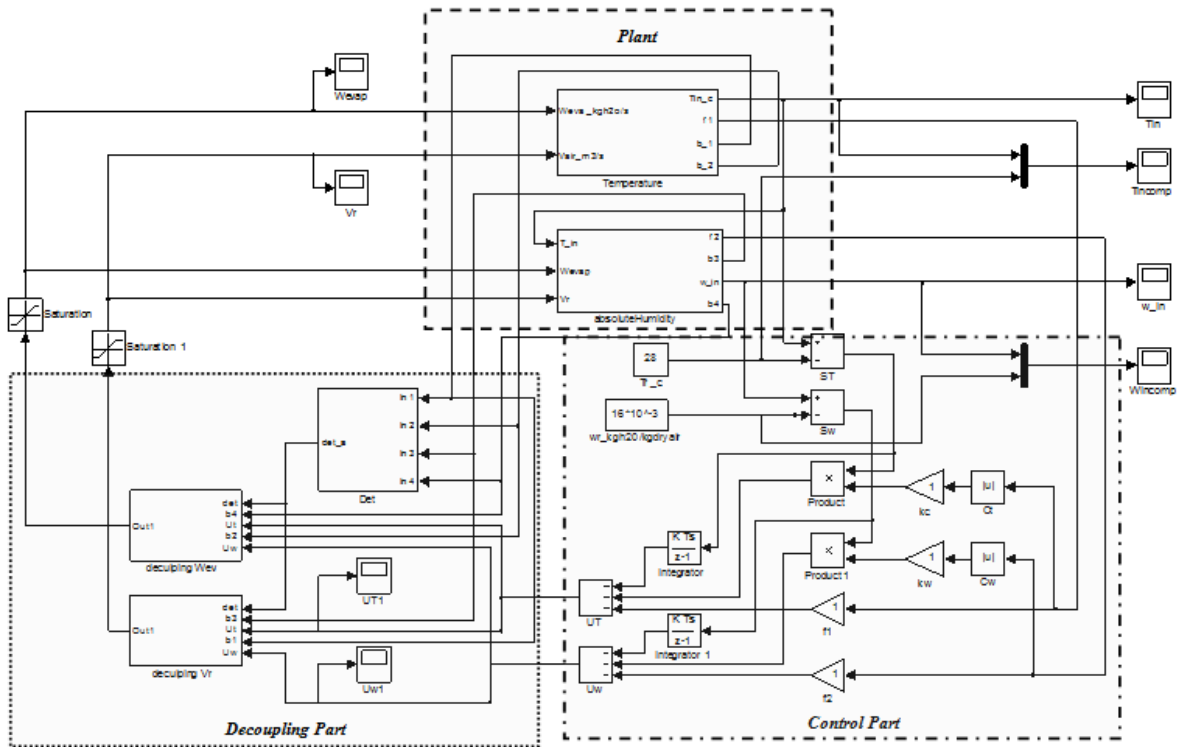
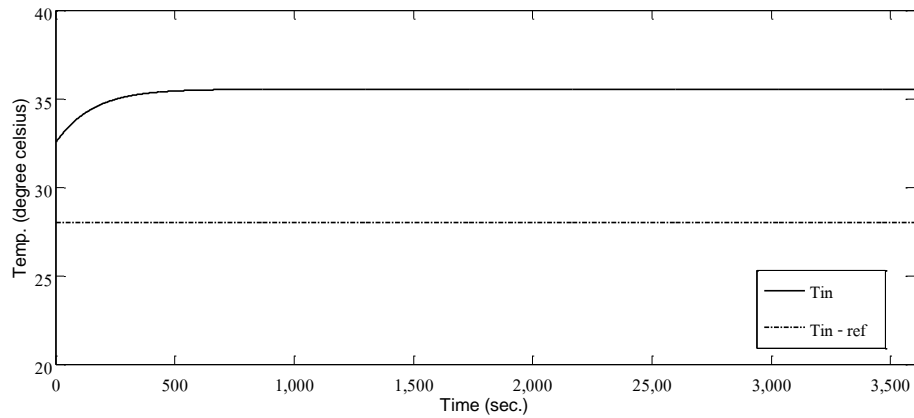
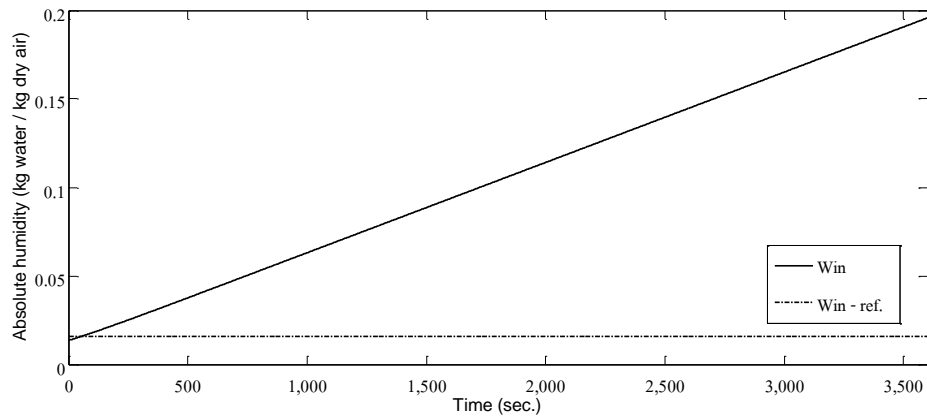

Figure 9 shown Block diagram of the closed Loop Control System in Matlab simulink.



(a)



(b)

Figure 10 (a) the response of internal temperature ( $T_{in}$ )

(b) the response of internal absolute humidity ( $w_{in}$ ) of Case 1

From Figure 10 a system has no control condition in house. Internal temperature are increasing until equal to the external environment is stable. While the internal moisture is increase the accumulation of water vapor in the air. Can be add up to the saturation at that temperature. Which consider the environment that arise cannot be feed the chickens in the house with comfortable. That making productivity, quality and quantity is not required.

#### 4.2 Case 2 when the system is $\Delta T_{out-in}$ and $\Delta w_{in-out}$ are zero

For the system are control internal conditions. Setting error values from the difference of temperature inside and outside ( $\Delta T_{out-in}$ ) and error values of the difference of moisture inside and outside ( $\Delta w_{in-out}$ ) are zero. The results of the simulation control program based on this case are shown as Figure 11 and Figure 12.

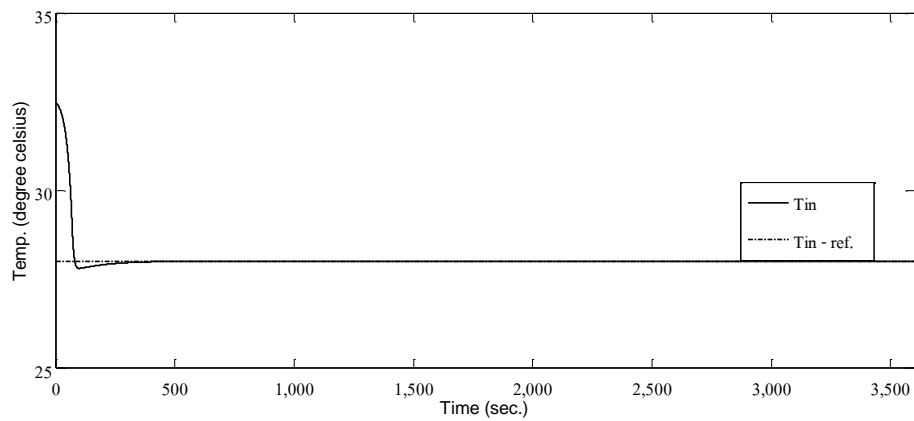

(a)

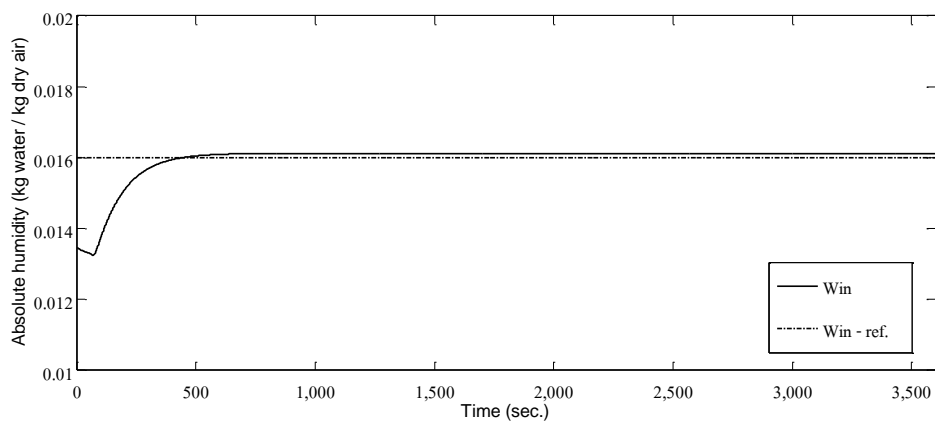

(b)

Figure 11 (a) the response of internal temperature ( $T_{in}$ )  
(b) the response of internal absolute humidity ( $w_{in}$ ) of Case 2

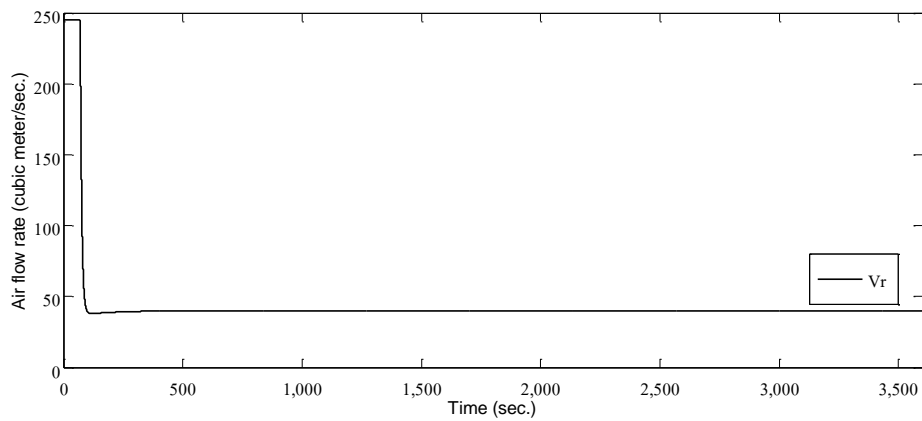

(a)

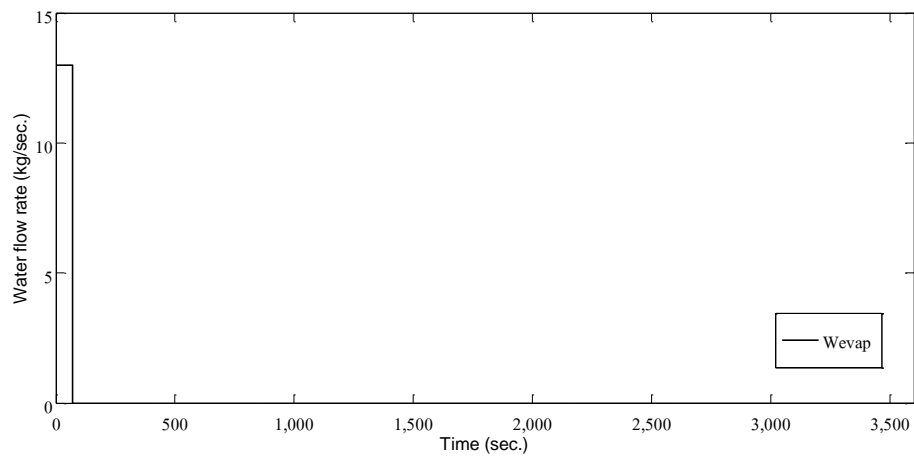

(b)

Figure 12 the control signal (a)  $V_R$  and (b)  $w_{ev}$  of Case 2.

Figure 11 and 12 seen that when the system is controlled by the state which has  $\Delta T_{out-in}$  and  $\Delta w_{in-out}$  are zero. Control system can control the house's condition to the desirable be precise. Which allows feed the chickens in the house more efficiently.

**4.3 Case 3 when the system is  $\Delta T_{out-in}$  and  $\Delta w_{in-out}$  are not zero respective given above.**

For the system are control internal conditions. Setting error values from the difference of temperature inside and outside ( $\Delta T_{out-in}$ ) and error values of the difference of moisture inside and outside ( $\Delta w_{in-out}$ ) are  $1 \sin \frac{2\pi}{900} t$  and  $1 \times 10^{-3} \sin \frac{2\pi}{900} t$  respectively. (Simulated the uncertainty of measurement.) The results of the simulation control program based on this case are shown as Figure 13 and Figure 14.

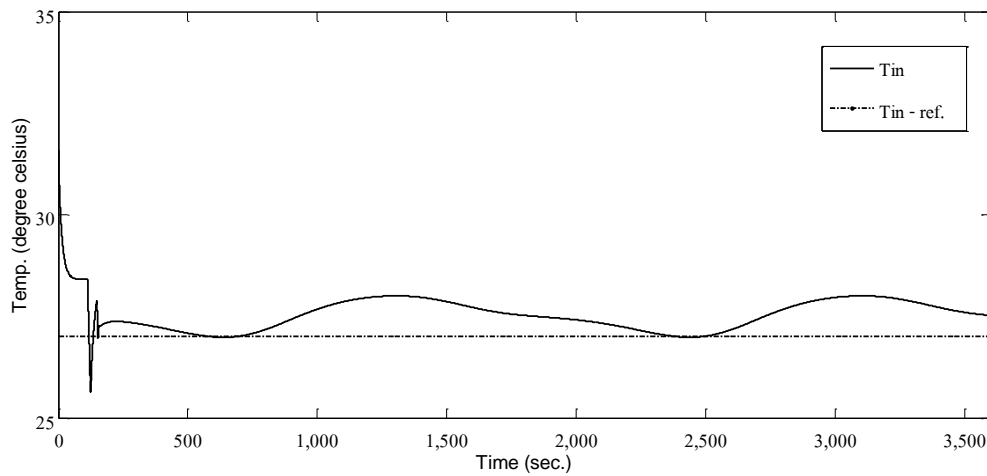

(a)

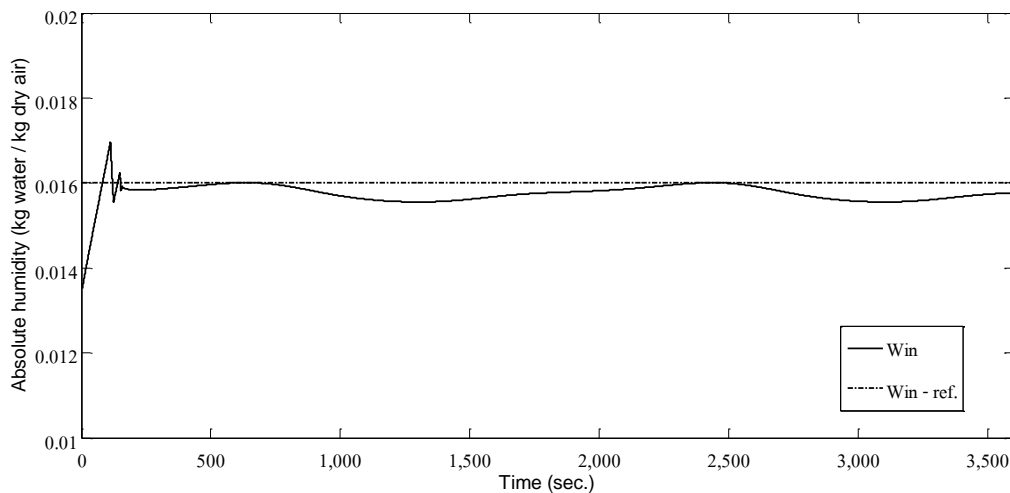

(b)

Figure 13 (a) The response of internal temperature ( $T_{in}$ )  
(b) The response of internal absolute humidity ( $W_{in}$ ) of Case 3.

Figure 13 and 14 seen that when the system is controlled by the state which has  $\Delta T_{out-in}$  and  $\Delta W_{in-out}$  are  $1 \sin \frac{2\pi}{900} t$  and  $1 \times 10^{-3} \sin \frac{2\pi}{900} t$  respectively. Control system also control internal condition of house according to desire. By occur the oscillations of the response slightly little from the reference. The control signal from this model (Figure 14) can

order a device is working under the restrictions of the device. At beginning the system will takes a while to adjust. The equation for this control, it sends a signal to the control system is substantially. And steady-state. It shows clearly that even if the system is disturbed. Controller internal condition will go on. For feed Chicken in closed house to be properly.

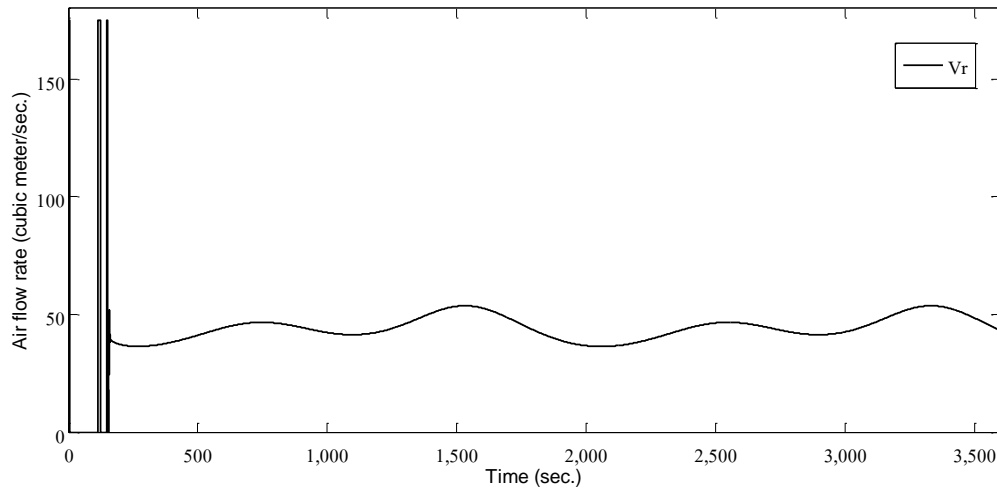

(a)

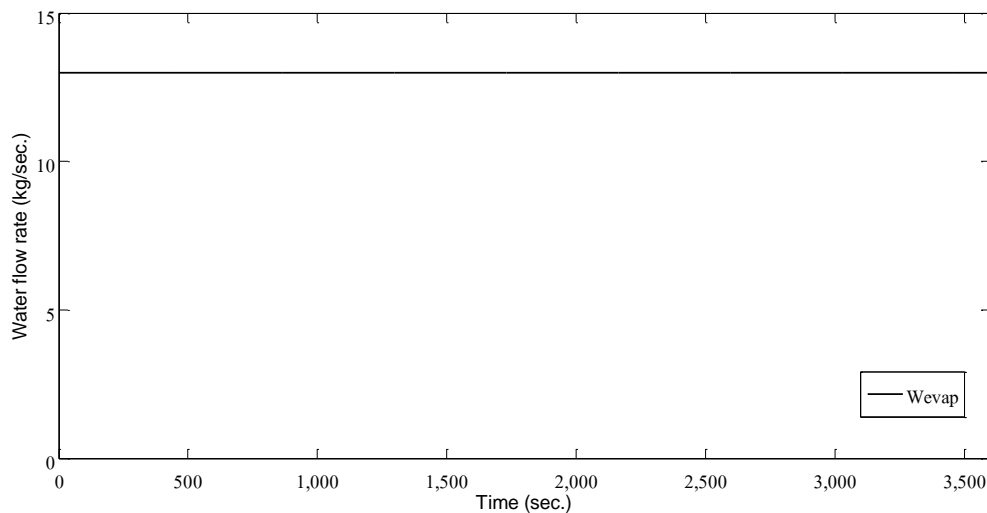

(b)

Figure 14 the control signal (a)  $V_R$  and (b)  $w_{ev}$  of Case 3.

### 5. conclusion

All of above that mathematical model which conducts compared with the measurements and data from the actual house are similar and tended to be in the same direction. The error with accuracy levels can accept to simulate control system. So do experiment and control the system to consider internal temperature response ( $T_{in}$ ) and internal humidity ( $w_{in}$ ) that occur from controllable system. It can see that, if are used in the future.

The rule control designed can use as a guide in developing a system that has capabilities and benefit with installation the system on the poultry house. In order to allow feed the chickens in the close house properly when the weather conditions are change.

### Acknowledgement

This research was supported by Cleaner Technology Internship Program, Khon Kaen



University Node and Faculty of Engineering,  
Khon Kaen University, Thailand.

### References

- [1] Anusorn Rattanathanaopat, 2546, **Improving in Efficiency of Evaporative Cooling in Poultry**, Department of Energy Technology, King Mongkut's University of Technology Thonburi, Bangkok.
- [2] Barmish, B. R. and Leitmann, G. (1982). On ultimate boundedness control of uncertain systems in the absence of matching assumption. **IEEE Transactions on Automatic Control**, **27** (1), 153-158.
- [3] Bom, Gret Jan and etc., 1999, **Evaporative Air-Conditioning**, Washington, D.C., U.S.A, The World Bank
- [4] Camargo, Jose Rui, Ebinuma, CarlosDaniel and Silveira, Jose luz , 2005. **Experimental erformance of a direct evaporative cooler operating during summer in a Brazilian city**. Intl. J. Refrig., 28(7), 1124-1132.
- [5] Corless, M. J. and Leitmann, G. (1981). Continuous state feedback guaranteeing uniform ultimate boundedness for uncertain dynamic systems. **IEEE Transactions on Automatic Control**, **26** (5), 1139-1144.
- [6] Daskalov, et al. , 2005. "Non-linear Adaptive Temperature and Humidity Control in Animal Buildings" **Bio systems Engineering** 93 : 1–24
- [7] Giabaklou, Z. and Ballinger, J.A., 1996, "A Passive Evaporative Cooling System by Natural Ventilation," **Building and Enviroment**, Vol.31, No. 6 , pp. 503-507.
- [8] João M. D. Pimenta and Wagner P. De Castro, 2005, **ANALYSIS OF DIFFERENT APPLICATIONS OF EVAPORATIVE COOLING SYSTEMS**, Department of Mechanical Engineering, University of Brasilia.
- [9] Lawrence, S.A. and Tiwari, G.N., 1989, " Performance Study of an Evaporative Cooling System for a Typical House in Port Moresby," **Solar & Wind Technology**, Vol.6, No.6, pp.717-724.
- [10] Mills, A F., 1999, **Basic Heat & Mass Transfer**, California, Prentice Hall, pp. 274-276, 842-844.
- [11] Prapas Roengruen, Songsri Roengruen, Taweeapol Suesut, Viriya kongrata ,Suphan Kulphanich, **A Studying Of Automatic Control System On Poultry House**, Department of Instrumentation Engineering, Faculty of Engineering, King Mongkut's Institute of Technology Ladkrabang, Bangkok
- [12] Prayut Neamtang, 2546, **Reduction of Heat Loads Through Poultry Roof**, Department of Energy Technology, King Mongkut's University of Technology Thonburi, Bangkok.
- [13] Radpukdee, T. and Jirawattana, P. (2009). Uncertainty learning and compensation: an application to pressure tracking of an electro-hydraulic proportional relief valve. **Control Engineering Practice**, **17(2009)**, **291-301**
- [14] Simmons, J.D. and Lott, B.D., 1996, "Evaporative Cooling Performance Resulting From Changes In Water Temperature," **Applied Engineering in Agriculture**, Vol. 12, No. 4, pp. 497-500.



- [15] Slotine, J.J.E. and Li, W. (1991). **Applied Nonlinear Control**. New Jersey: Prince-Hall International Inc., USA.
- [16] Sodha, M.S., Sawhney, R.L., Kaur, J. and Singh, S.P., 1991, "Thermal Performance of a Room Coupled to an Evaporative Cooling Tower," **Proceedings of The Biennial Congress of The International Solar Energy Society**, Vol. 3, Part 3, August 19-23, Colorado, USA., pp. 3095-3100.
- [17] Thepa, S., Kirtikara, K., Hirunlabh, J. and Khedari, J., 1999, "Improving Indoor Conditions of a Thai-style Mushroom House by Means of An Evaporative Cooler and Continuous Ventilation," **Renewable Energy**, Vol. 17, pp. 359-369.
- [18] Yunus, A.C. and Michael, A.B., 1989, **Thermodynamics : An Engineering Approach**, Singapore